

Print exam correction:
Section A, Q5, Q6; Section C - Case Study
Specifications; Section C, Q9.
The spelling of the joint 'mortise' was
incorrectly spelled 'mortice'. There are four
instances of this spelling error.

SUPERVISOR TO ATTACH
PROCESSING LABEL HERE

--	--	--	--	--	--	--	--	--

Write your **student number** in the boxes above.

Letter

VET Furnishing

Question and Answer Book

VCE Examination – Friday 8 November 2024

- Reading time is **15 minutes**: 9.00 am to 9.15 am
- Writing time is **1 hour 30 minutes**: 9.15 am to 10.45 am

Materials supplied

- Question and Answer Book of 24 pages
- Detachable Insert for Section C in the centrefold
- Multiple-Choice Answer Sheet

Approved materials

- One scientific calculator

Instructions

- Follow the instructions on your Multiple-Choice Answer Sheet.
- At the end of the examination, place your Multiple-Choice Answer Sheet inside the front cover of this book.
- Detach the Insert for Section C from the centre of this book during reading time.

Students are **not** permitted to bring mobile phones and/or any unauthorised electronic devices into the examination room.

Contents	pages
Section A (20 questions, 20 marks) _____	2–7
Section B (13 questions, 48 marks) _____	8–14
Section C (9 questions, 32 marks) _____	16–23

Section A – Multiple-choice questions

Instructions

- Answer **all** questions on your Multiple-Choice Answer Sheet.
 - Choose the response that is **correct** or that **best answers** the question.
 - A correct answer scores 1; an incorrect answer scores 0.
 - Marks will **not** be deducted for incorrect answers.
 - No marks will be given if more than one answer is completed for any question.
 - Unless otherwise indicated, the diagrams in this book are **not** drawn to scale.
-

Question 1

Which one of the following tools is used to make a dowel joint?

- A. drill
- B. router
- C. plane
- D. chisel

Question 2

Which of the following glues is most suitable for outdoor use?

- A. polyurethane
- B. contact adhesive
- C. polyvinyl acetate (PVA)
- D. cyanoacrylate (CA)

Question 3

If a plane blade has a grinding angle of 25 degrees, what is the honing angle?

- A. 5 degrees
- B. 10 degrees
- C. 25 degrees
- D. 30 degrees

Question 4

When reassembling the plane blade with the backing iron, how far apart should the tips be?

A. flush

B. 1.5 mm apart



C. 3 mm apart

D. 5 mm apart

**Question 5**

A bridle joint is being cut out of 24 mm thick Victorian ash timber.



How far apart should the pins on a mortise gauge be set?

A. 6 mm

B. 8 mm

C. 16 mm

D. 18 mm

Question 6

Which of the following best describes the function of a bench hook?

A. It fits through a mortise on the bench and stops timber from slipping.

B. It hangs tools under the bench like a shadow board for storage.

C. It is a well in the bench to stop tools falling onto the floor.

D. It holds timber while sawing and to protect the bench.

Question 7

A cabinet with five drawers and five doors is being made.

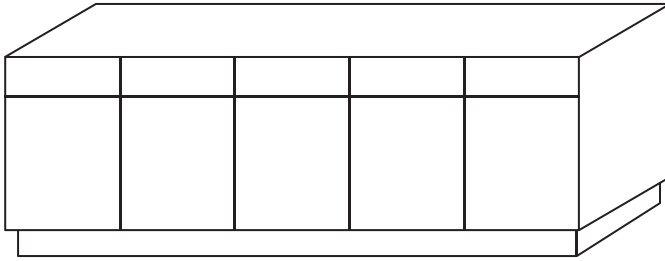

How much hardware is required?

- A. five handles, five hinges and five sets of drawer runners
- B. 10 handles, five hinges and five sets of drawer runners
- C. 10 handles, 10 hinges and five sets of drawer runners
- D. 10 handles, 10 hinges and 10 sets of drawer runners

Question 8

When cutting timber with a tenon saw, how much space should be allowed for a saw cut to minimise waste?

- A. 5 mm
- B. 10 mm
- C. 25 mm
- D. 30 mm

Question 9

Which of the following is the most appropriate tool to use when checking an assembled carcass for square?

- A. combination square
- B. framing square
- C. tape measure
- D. scale rule

Question 10

Which of the following tools is best suited to finishing the concave curved edge of cabinet rails after being cut on a bandsaw?

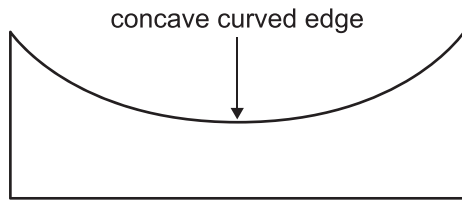

A. smoothing plane



B. block plane

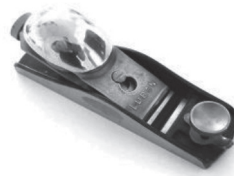

C. spokeshave



D. try plane

**Question 11**

When driving a screw into two pieces of solid timber, the size of the clearance hole should be

- A. slightly more than the diameter of the shank.
- B. slightly less than the diameter of the core.
- C. equal to the diameter of the screw head.
- D. equal to the diameter of the core.

Question 12

Following the glue up of two bedside tabletops, the excess glue that is squeezed from the joints should be

- A. scraped off with a chisel or blade, smearing the glue.
- B. allowed to cure for 24 hours and then removed.
- C. wiped off with a soaking wet cloth.
- D. wiped off with a damp cloth.

Question 13

Scale drawings are used when planning furniture projects

- A. to allow the whole project to be shown on a single sheet of paper.
- B. to make furniture templates from.
- C. only when the item is built in.
- D. for complex projects only.

Question 14

Susan is sanding the top surface of bedside cabinets.

Which motion should she apply with the block and sandpaper?

- A. circular
- B. across the grain
- C. along the grain
- D. diagonal to the grain

Question 15

What type of handsaw is used to cut metal bolts or screws?

- A. tenon saw
- B. coping saw
- C. bead saw
- D. hacksaw

Question 16

John is making a dining table. The top is 900 mm × 900 mm and it has a 30 mm overhang perimeter. The legs are 690 mm × 45 mm × 45 mm, which are loose tenoned into the rails.

What is the finished length of the rails for John's dining table?

- A. 750 mm
- B. 810 mm
- C. 825 mm
- D. 870 mm

Question 17

Tops are needed for 20 occasional tables. The tops measure 580 mm in diameter.

How many 2400 mm × 1200 mm sheets of veneered particle board (VPB) are required?

- A. two
- B. three
- C. four
- D. five

Question 18

Muhamad needs seven bolts, 14 washers and seven wing nuts to complete a project. The hardware store sells bolts in packets of five, washers in packets of five and wing nuts in packets of three.

How many packets of hardware will Muhamad need in total?

- A. five packets
- B. six packets
- C. seven packets
- D. eight packets

Question 19

Where would a lapped dovetail joint be used?

- A. tabletop
- B. leg and rail
- C. drawer front
- D. cabinet door

Question 20

Outdoor furniture is being assembled with a polyurethane adhesive.

Which document must be consulted to understand safe working practices when using the polyurethane adhesive?

- A. SOP
- B. SDS
- C. SWMS
- D. SCA

Section B – Short-answer questions

Instructions

- Answer **all** questions in the spaces provided.
- Write your responses in English.
- Unless otherwise indicated, the diagrams in this book are **not** drawn to scale.

Question 1 (6 marks)

Complete the table below by identifying two measurement tools and describing a use for and limitation of each tool.

Measurement tool	Use	Limitation
<i>tape measure</i>	<i>taking internal and external measurements</i>	<i>not appropriate for very small measurements</i>

Question 2 (3 marks)

Fred has been asked to make a boardroom table for a client.

The dimensions of the boardroom are 9 m x 6 m. The client would like the table to be as big as possible; however, there must be a 2 m clearance between all four edges of the table and the walls of the boardroom.

For people to be seated comfortably, each chair requires 900 mm of space.

Complete the table below to show the maximum width and length of the table and the maximum number of chairs that would allow people to be seated comfortably.

maximum width	
maximum length	
maximum number of chairs	

Question 3 (6 marks)

After checking the quality of the cutting edge of her bevelled edge chisel, Jo noticed that the edge is severely chipped and needs to be sharpened.

Complete the table below by filling in the order of the steps she should follow.

Step no.	Description of step
	Inspect the cutting edge prior to use.
	Using a strop or clean piece of timber, remove the excess burr.
	Hone the cutting angle of the chisel on the sharpening stone using a figure-8 motion.
	Check the rest and wheel of the bench grinder, including coolant.
	Grind the chisel, without overheating, to an angle of 25°.
	Hone the back of the chisel on the sharpening stone, keeping it perfectly flat.

Question 4 (4 marks)

Albert is making two lamp tables out of solid timber. He wants to have timber that looks good, is strong, does not dent easily and is reasonably stable.

Outline four timber characteristics that may help him choose the most suitable timber.

- _____
- _____
- _____
- _____

Question 5 (4 marks)

Identify and explain two advantages of using solid timber instead of manufactured boards when making furniture.

Advantage 1 _____

Explanation _____

Advantage 2 _____

Explanation _____

Question 6 (2 marks)

The drawings below show a circle representing the top view of a slotted screw.

Using the circles provided, draw the top view of a Phillips screw and a Pozidriv screw.

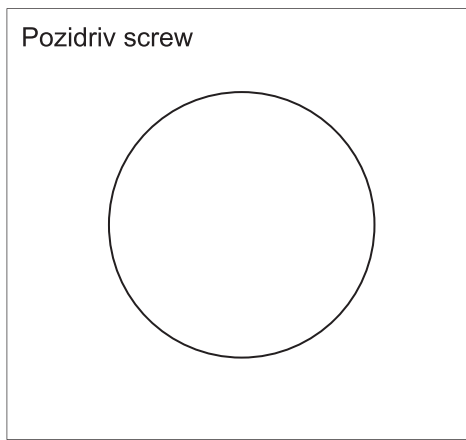
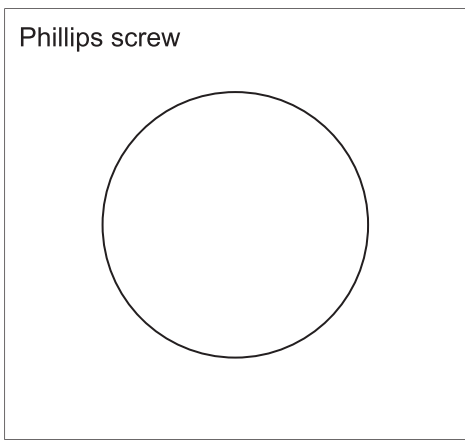
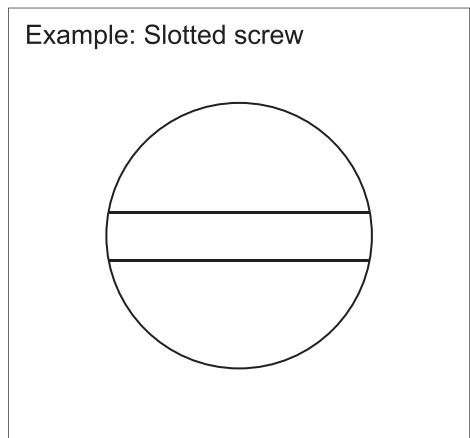

Do not write in this area.

Question 7 (2 marks)

When using a plane on solid timber, what causes the waste to be too thick and more like a veneer than a shaving?

Question 8 (3 marks)

A tape measure is used for taking both internal and external measurements.

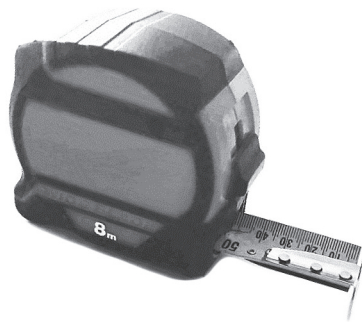

- a. Describe what happens with the chrome end of the tape when measuring. 1 mark

- b. Explain how to compensate for the issue you described in **part a**. 2 marks

Do not write in this area.

Question 9 (4 marks)

Jane is making an oval mirror using 12 mm thick, solid mahogany timber. She will be making it in two layers to maximise strength. Each layer has four sections, as shown in the image in **part a**.

- a. Draw the grain direction on the layers below in each section, taking into consideration the grain direction for maximum strength.

3 marks

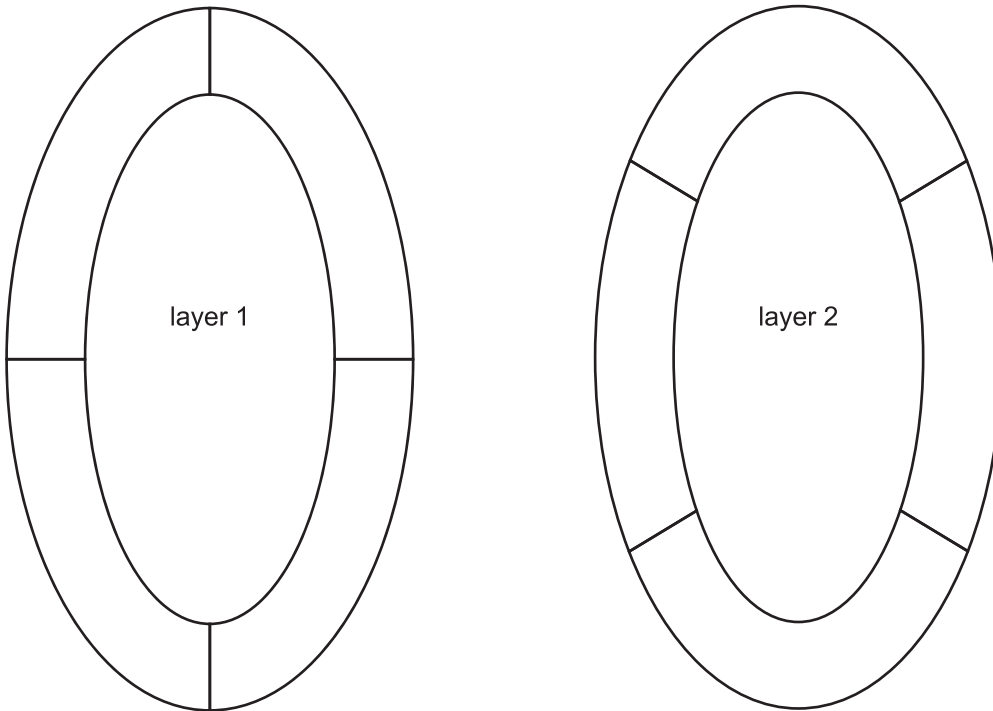

- b. Name the type of joint that she will use to join the ends of each segment.

1 mark

Question 10 (6 marks)

Name each of the hinges in the images below and give one advantage and one disadvantage for each.

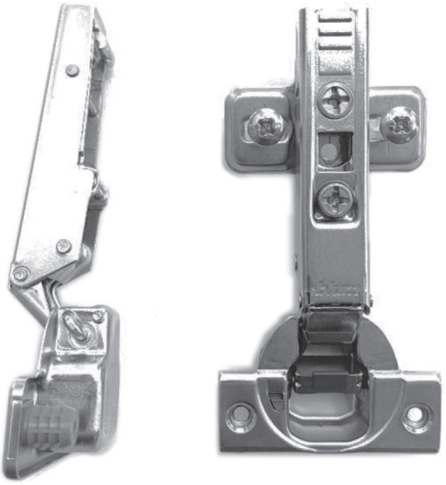
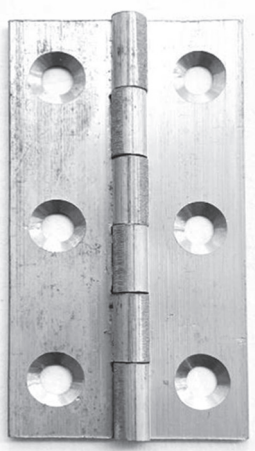
	
Name	Name
Advantage	Advantage
Disadvantage	Disadvantage

Question 11 (2 marks)

The cabinet-making sector is increasingly focused on meeting environmental standards in the workplace.

Describe what 'best practice' is when dealing with offcuts of all sizes from behind a panel saw.

Do not write in this area.

Question 12 (4 marks)

Jimmy is using veneered particle board (VPB) to construct his entertainment unit, and needs to apply an iron-on edge veneer by hand, leaving 2 mm overhang on either face.

Explain how he can remove the excess veneer edging both with a file and sandpaper, and with a cabinet scraper and sandpaper.

file and sandpaper _____

cabinet scraper and sandpaper _____

Question 13 (2 marks)

The door on a cabinet provides security for items, while a drawer on a cabinet provides storage and accessibility. Both the door and the drawer also have the potential to enhance the appearance of the cabinet.

- a. What is the industry-accepted gap on all four edges of a fitted door on a sideboard cabinet?

1 mark

- b. What is the industry-accepted gap on the top edge of a drawer side that is running on a timber drawer runner?

1 mark

Do not write in this area.

Do not write in this area.

This page is blank.

Examination continues on the next page.

Section C – Case study

Instructions

- Please remove the Insert from the centre of this book during reading time.
 - Use the case study provided below and the working drawings in the Insert to answer the questions in this section.
 - Use explanatory diagrams, charts and sketches if you believe they will improve your answers.
 - Answer **all** questions in the spaces provided.
 - Write your responses in English.
 - Unless otherwise indicated, the diagrams in this book are **not** drawn to scale.
-

Read the following specifications together with the working drawings on pages 2 and 3 of the Insert.

Specifications

A client requires a storage box with drawers to store various items and equipment, with the following specifications.

Dimensions: 1000 mm × 700 mm × 600 mm

Finish: 70% gloss nitrocellulose lacquer spray

Materials:

- carcass – 20 mm kauri pine
- solid timber kauri pine unless otherwise indicated
- drawer sides and backs – 12 mm silky oak
- drawer bottoms – 9 mm plywood

Carcass:

- bottom corners of the carcass – through dovetailed
- carcass shelf – box or finger joint on both ends into the side panels
- front and back rails – biscuited into the side panels
- drawer runners – tongue and grooved into the back of the front rail and screwed to the side panels
- carcass front panel – dominoed into the side panels, and to the top face of the shelf
- carcass back – butt biscuited to the inside of either side panel

Drawers:

- drawer fronts – 20 mm kauri pine and sit flush with all front edges of the side panels, front rail, shelf and bottom panel
- drawer sides and backs – 12 mm thick silky oak
- drawer fronts and sides – 2 mm smaller than the carcass
- lapped dovetail drawer construction for the drawer fronts and drawer sides
- drawer backs – housed into the drawer sides 6 mm deep and 10 mm in from the back edge
- plywood drawer bottoms – grooved 5 mm into the drawer front and drawer sides

Lid:

- all surfaces that make up the top face of the lid – flush
- all outer corners of the lid – bridle joint construction
- muntin – stopped mortise and tenoned, with the length of the tenon being 50 mm
- panels – rebated on all four edges with a 10 mm × 7.5 mm rebate
- all rails, stiles and muntin – grooved 10 mm × 7.5 mm, 7.5 mm down from the top face
- lid – hinged to the top edge of the back panel using 100 mm brass butt hinges, 75 mm in from either end and a third hinge exactly in the centre
- both panels – 15 mm thick

Question 1 (5 marks)

Complete the table below by filling in the missing information in the bold boxes using the working drawing and specifications.

Cutting list							
Item no.	Item name	No. of pieces	Length (mm)	Width (mm)	Thickness (mm)	Remarks	Material
Carcase							
1	front panel	1	960	298	20		kauri pine
2	back panel	1		680	20		kauri pine
3	side panel	2	680	600	20		kauri pine
4	bottom panel	1	1000	595	20	through dovetail joint	kauri pine
5	shelf	1	1000	585	20	finger joint	
6	front rail	1	960	60	20		kauri pine
7	back rail	1	960	60	20		kauri pine
8	drawer runner	2	520	40	20		Victorian ash
Top / Lid							
9	front rail	1		75	20		kauri pine
10	back rail	1	1000	75	20		kauri pine
11	stiles	2	600	75	20		kauri pine
12	muntin	1	550	75	20	50 mm tenon into rails	kauri pine
13	panel	2	407.5	470	15		kauri pine

Top drawer							
14	drawer front	1	957	179		lapped dovetail to side	kauri pine
15	drawer side	2	567	179	15		silky oak
16	drawer back	1	945	164	15	housed 6 mm deep into sides	silky oak
17	drawer bottom	1	943	542	9	5 mm deep grooves	plywood
Bottom drawer							
18	drawer front	1	957	139	20	lapped dovetail to side	kauri pine
19	drawer side	2	567	139	15		silky oak
20	drawer back	1	945	124	15	housed 6 mm deep into sides	silky oak
21	drawer bottom	1	943	542	9	5 mm deep grooves	

Do not write in this area.

Question 2 (2 marks)

As an alternative to the finger joint that joins the shelf to the side panels, name a traditional joint that is strong enough to carry the weight. Explain your choice.

Name _____

Explanation _____

Question 3 (2 marks)

The domino joint is used to join some components of the storage box.

What are **two** other situations where a domino joint may be used on furniture pieces?

Question 4 (5 marks)

The corner bridle has two parts: the rail and the stile. The rail has a tenon.

In the table below, describe the five missing steps to create the tenon using hand tools.

Step no.	Description of step
1	<i>Mark out tenon using a pencil, ruler, try square and marking gauge.</i>
2	
3	
4	
5	
6	
7	<i>Using a chisel, guide block and wooden mallet, square up the two shoulders.</i>

Question 5 (3 marks)

The rails, muntin and stiles need to be cut for the storage box lid.

Name the power tool below and give two reasons why this tool should be used for this task.

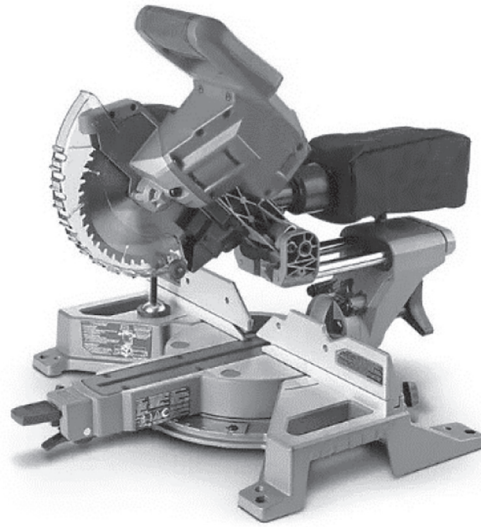

Name _____

Reason 1 _____

Reason 2 _____

Question 6 (5 marks)

a. Label the parts of the rubber mallet shown below.

4 marks

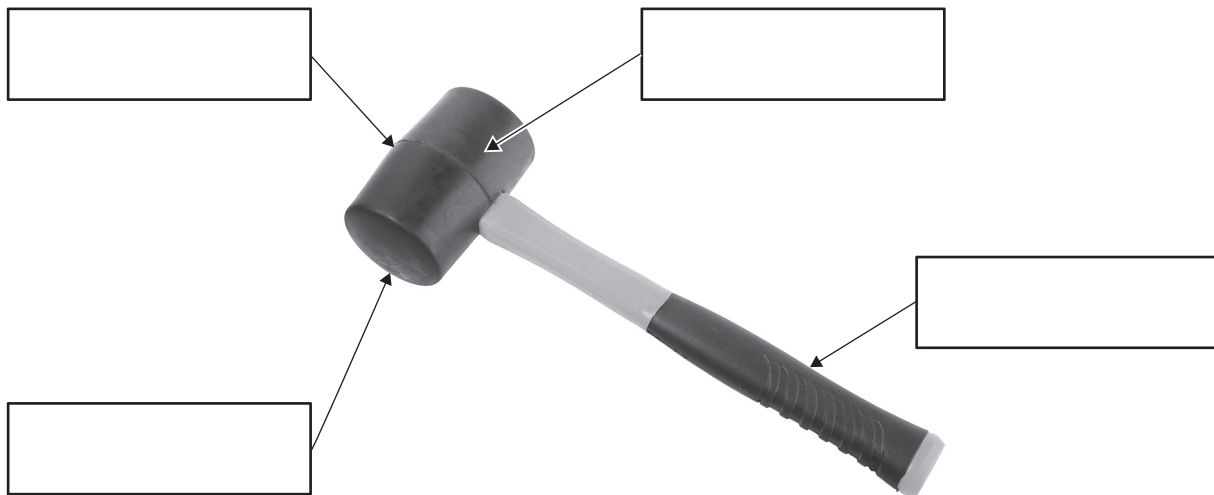

Source: Albo003/Shutterstock.com

b. Describe **one** application of the rubber mallet in the storage box project.

1 mark

Do not write in this area.

Question 7 (2 marks)

What does the term 'flush' mean in relation to components of furniture? Provide an example.

Question 8 (4 marks)

When constructing a drawer box, a lapped dovetail is used to join the front corners.

- a. Which joint would be the most suitable for joining the back corners connecting the back to the sides? 1 mark

- b. How deep would the back be recessed into the side? 1 mark

- c. Using the joint identified in **part a**, sketch the drawer side and back below. 2 marks

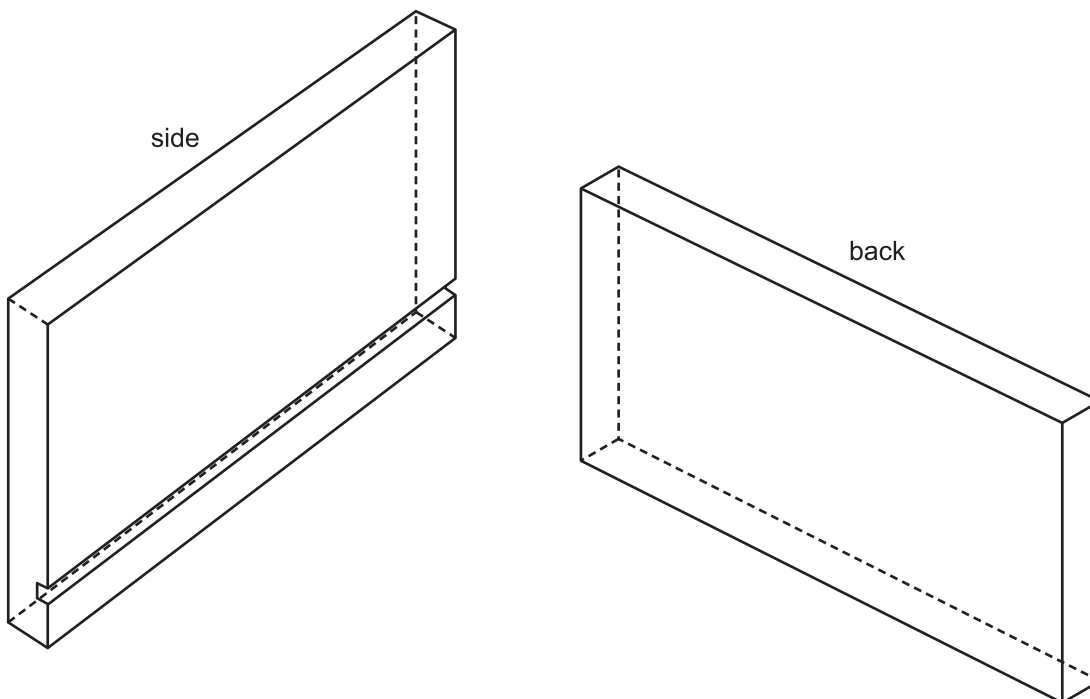

Question 9 (4 marks)

On the drawing below, sketch the corner bridle joints that will be used in the lid of the storage box. Show the faces and shoulders for both the tenon and the mortise.

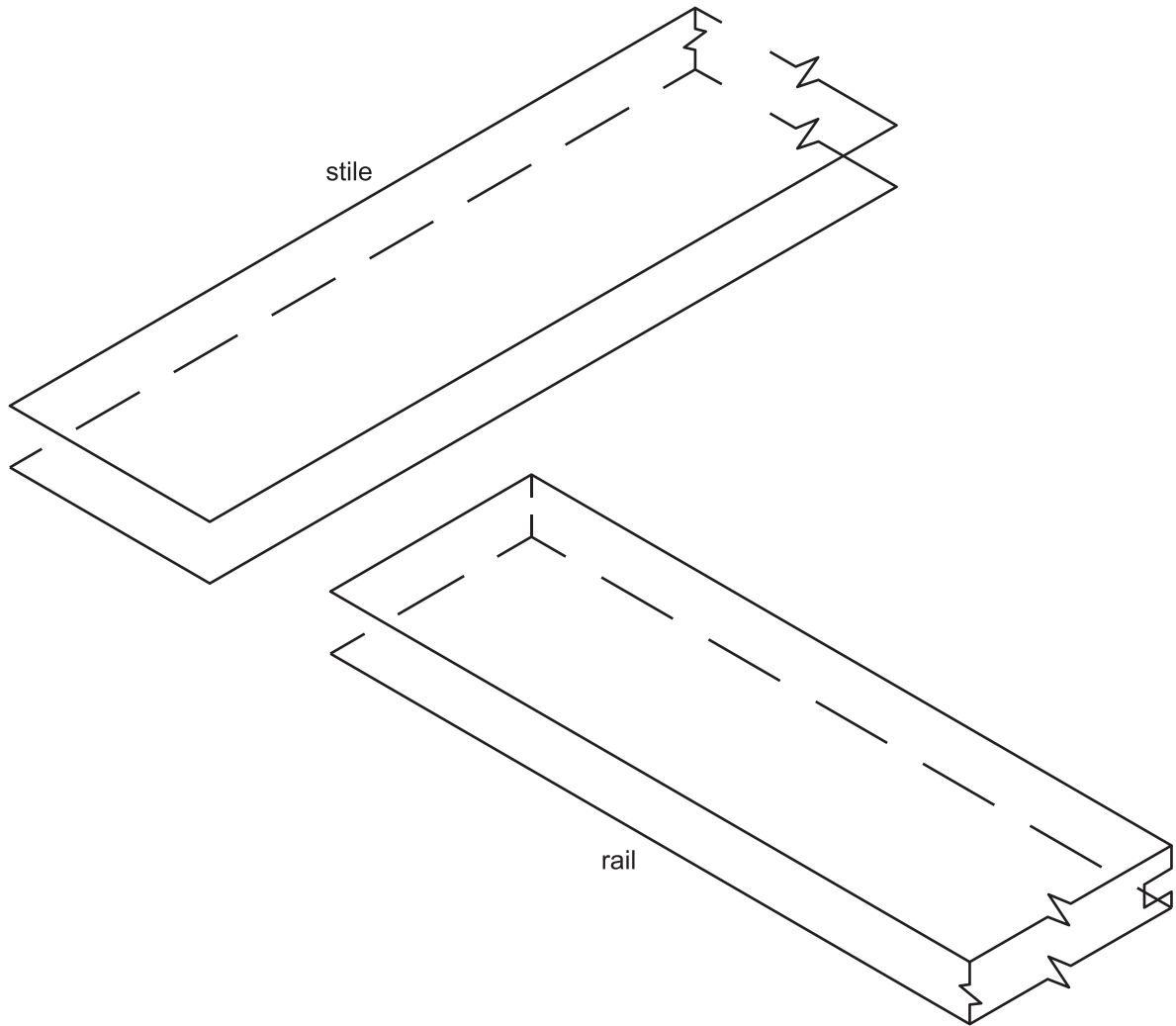

Do not write in this area.

VET Furnishing

Insert for Section C

Please remove from the centre of this book during reading time.

You may keep this Insert.

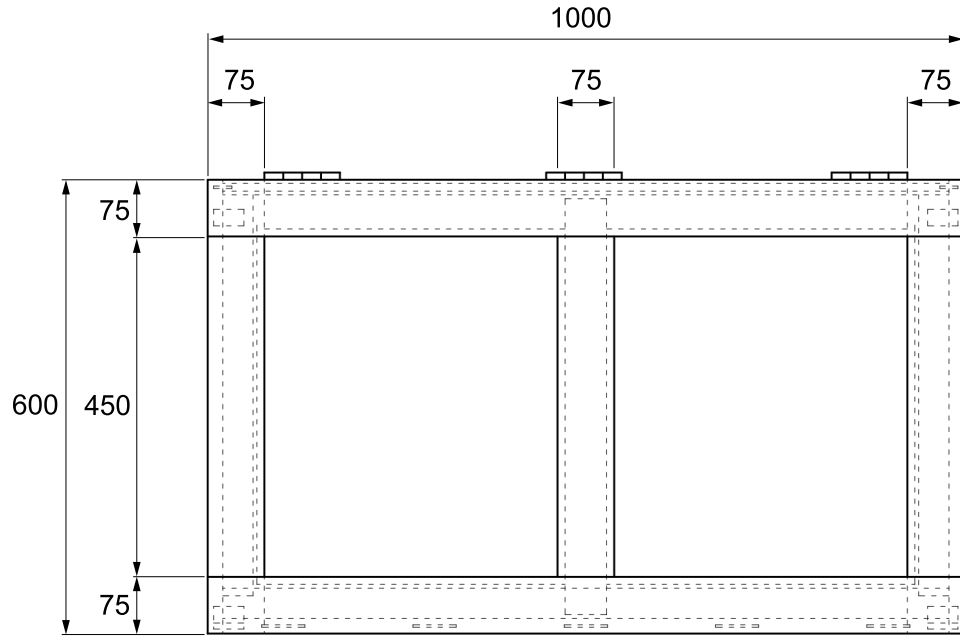

TOP VIEW

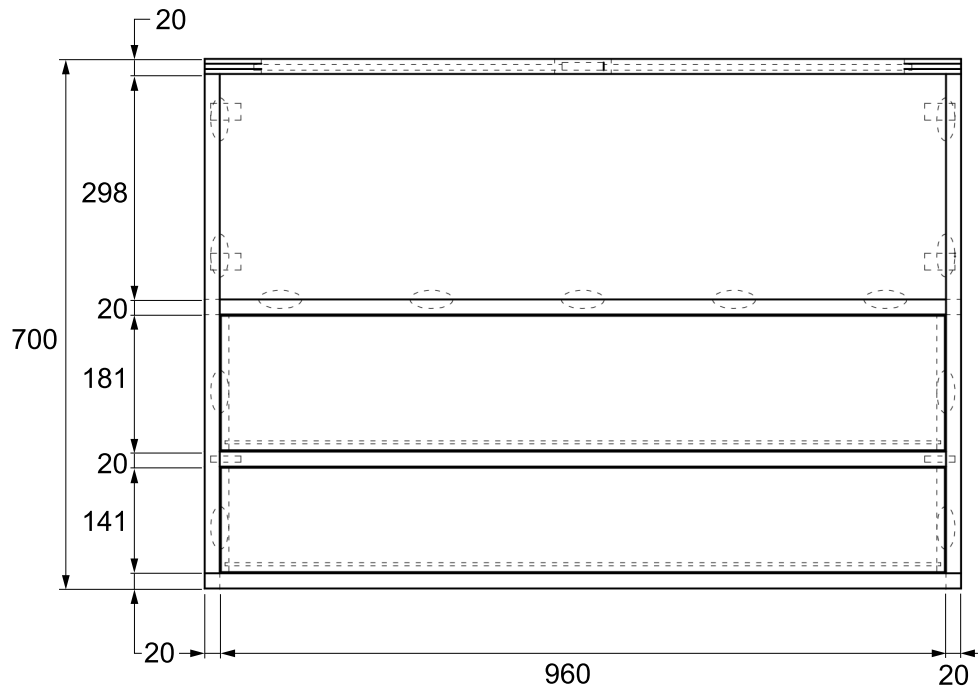

FRONT VIEW

Storage Box

Address: Melbourne

Ph:

Fax:

email:

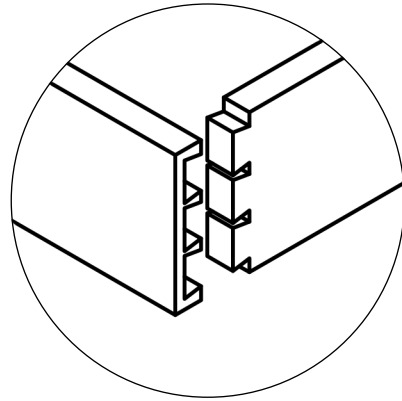

LAPPED DOVETAIL

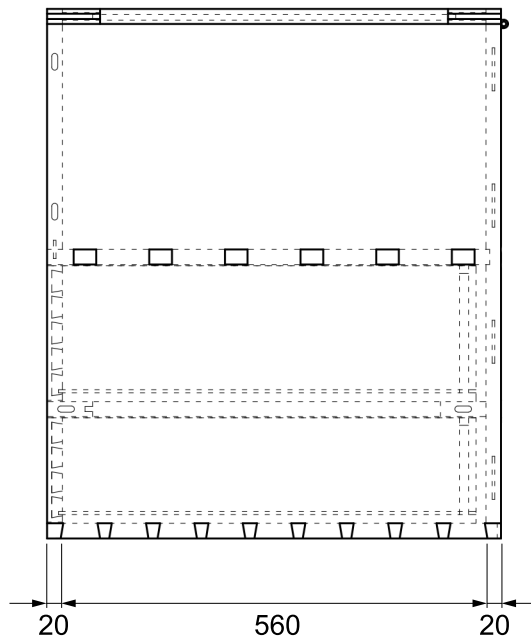

SIDE VIEW

CLIENT	PROJECT Storage Box	DRAWING Storage Box #1		
		DATE 01/02/24	No. IN SET 1	THIS DRAWING 1
		DRAWING BY	DRAWING REFERENCE	
		DESIGNED		
		SCALE 1:10	1/1	

This page is blank.